

PIONEER

Stereo Components



PIONEER ELECTRONIC CORPORATION



THE QUALITY STORY OF PIONEER

Quality comes with painstaking experience. And PIONEER has over 30 years of it. Our hundreds of dedicated engineers combine the latest knowledge audio state of the art with the highest quality material and components to provide the ultimate in performance PIONEER's exhaustive program of quality control is constantly maintained since we produce each single component on our own production lines. Each step along with the way is typical of PIONEER's dedication to quality craftsmanship. The end result: High Fidelity components designed and constructed to provide the pinnacle of sound reproduction combined with the gracious elegance of contemporary design.

**ALL SOLID STATE
RECEIVERS
TUNERS & AMPLIFIERS**





\$549.95



\$499.95



\$399.95

SX-2500

SX-2500 340 WATT AM/FM STEREO RECEIVER At 4 ohms this extraordinary Pioneer unit offers 340 watts (IHF) making it one of the powerful receivers available today at any price. Sensitive FM section features five IC's and 2 crystal filters for extreme selectivity. Station selector features motor-driven automatic tuning dial. Styling is contemporary.

Music Power: 340W (at 4Ω), 208W (at 8Ω)
 Harmonic Distortion: Less than 0.5% (at 1KHz rated output)
 Frequency Response: 20–70,000Hz ± 2dB
 FM Usable Sensitivity: 1.6μV (IHF)
 FM Separation: 40dB (at 1KHz)
 Tuning Range: FM: 87.5–108MHz; AM: 525–1,605KHz
 Audio Input: PHONO: MAG/CER/CRYSTAL, TAPE MONI, AUX, DIN jack, MAIN-IN
 Power Supply: 110, 120, 130, 220, 240V
 Dimensions: 19 1/8" (W) x 5 3/4" (H) x 15 1/8" (D)
 Weight: 33 lbs.

SX-9000

SX-9000 240 WATT AM/FM STEREO RECEIVER Big power, classic design and features new to any other stereo receiver now on the market make this Pioneer set perfect for any application. Includes reverberation amplifier/circuit, microphone mixing amplifier/circuit, much more. Sensitive FM section, too.

Music Power: 240W (at 4Ω), 150W (at 8Ω)
 Harmonic Distortion: Less than 0.5% (at 1KHz rated output)
 Frequency Response: 10–35,000Hz ± 1dB
 FM Usable Sensitivity: 1.6μV (IHF)
 FM Separation: 40dB (at 1KHz)
 Tuning Range: FM: 87.5–108MHz; AM: 525–1,605KHz
 Audio Input: PHONO: MAG (1, 2), AUX (1, 2), TAPE MONI (A, B) MICROPHONE (A, B), MAIN-IN
 Power Supply: 110, 120, 130, 220, 240V
 Dimensions: 20 9/16" (W) x 7 5/8" (H) x 13 9/16" (D)
 Weight: 34 lbs. 8 oz.

SX-1500TD

SX-1500TD 180 WATT STEREO RECEIVER The classic Pioneer stereo receiver, this powerful unit gives an output of 180 watts, is equipped with a microphone featuring microphone mixing and level control. This model handles up to three pairs of loudspeakers. It also has a pair of tuning meters.

Music Power: 180W (at 4Ω), 145W (at 8Ω)
 Harmonic Distortion: Less than 0.5% (at 1KHz rated output)
 Frequency Response: 10–100,000Hz ± 3dB
 FM Usable Sensitivity: 1.7μV (IHF)
 FM Separation: 38dB (at 1KHz)
 Capture Ratio: 0.7dB (at 98MHz)
 Tuning Range: FM: 87.5–108MHz; AM: 525–1,605KHz
 Audio Input: PHONO: MAG/CER, TAPE MONI, MIC, AUX, DIN jack, MAIN-IN
 Power Supply: 110, 120, 130, 220, 240V
 Dimensions: 18 1/16" (W) x 5 1/16" (H) x 14 1/2" (D)
 Weight: 25 lbs. 2 oz.



\$299.95

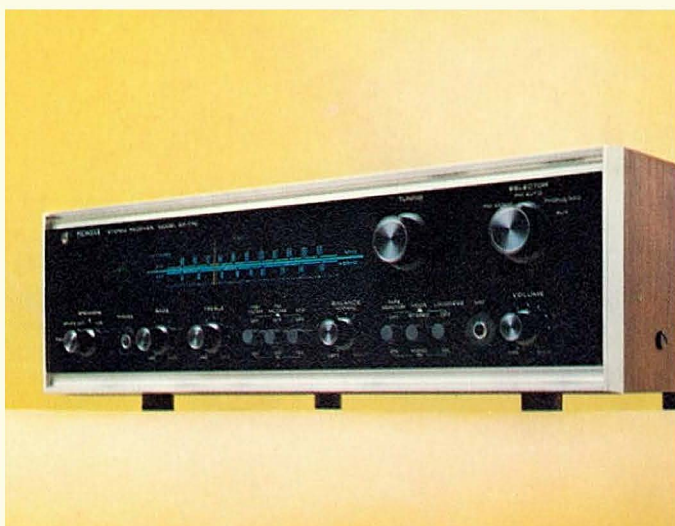

\$249.95



\$199.95

SX-990

SX-990 STEREO RECEIVER This all-solid state AM/FM stereo receiver meets all performance standards demanded by the sound enthusiast. Offering very low harmonic distortion, the handsome unit is unexcelled for performance.

Music Power: 130W (at 4Ω), 100W (at 8Ω)
 Harmonic Distortion: Less than 0.5% (at 1KHz rated output)
 Frequency Response: 10—100,000Hz ± 3dB
 FM Usable Sensitivity: 1.7μV (IHF)
 FM Separation: 42dB (at 1KHz)
 Capture Ratio: 1 dB (at 98 MHz)
 Tuning Range: FM: 87.5—108MHz; AM: 525—1,605KHz
 Audio Input: PHONO: MAG/CER, TAPE MONI/REC, TAPE HEAD, AUX, DIN jack, MICROPHONE JACK, MAIN-IN

Power Supply: 117V
 Dimensions: 18 1/16" (W) x 5 5/8" (H) x 14 1/2" (D)
 Weight: 25 lbs. 2 oz

SX-770

SX-770 STEREO RECEIVER Up-to-date circuitry and fine tuning sensitivity make this medium-powered AM/FM stereo receiver an extremely versatile performer. Low noise FET's and the combination of a low-noise silicon transistor and monolithic IC's provide exceptional FM tuning sensitivity and selectivity.

Music Power: 70W (at 4Ω), 52W (at 8Ω)
 Harmonic Distortion: Less than 0.8% (at 1KHz rated output)
 Frequency Response: 20—40,000Hz ± 3dB
 FM Usable Sensitivity: 1.8μV (IHF)
 FM Separation: 40dB (at 1KHz)
 Capture Ratio: 2.5 dB (at 98MHz)
 Tuning Range: FM: 87.5—108MHz; AM: 525—1,605KHz
 Audio Input: PHONO: MAG/CER, MIC, TAPE MONI/REC, AUX, DIN jack

Power Supply: 117V
 Dimensions: 16 15/16" (W) x 5 11/16" (H) x 13 3/4" (D)
 Weight: 21 lbs. 2 oz.

SX-440

SX-440 STEREO RECEIVER Pioneer's stereo design sensibility dominates this modestly-powered, yet high performance, AM/FM stereo receiver. The amplifier section offers a power output of 40 watts. For interference-free FM reception even in areas of station crowding, the unit has a FET and three-gang variable capacitor.

Music Power: 40W (at 4Ω), 33W (at 8Ω)
 Harmonic Distortion: Less than 1% (at 1KHz rated output)
 Frequency Response: 20—70,000Hz ± 3dB
 FM Usable Sensitivity: 2.5μV (IHF)
 FM Separation: 35dB (at 1KHz)
 Capture Ratio: 6 dB (at 98MHz)
 Tuning Range: FM: 87.5—108MHz; AM: 525—1,605KHz
 Audio Input: PHONO: MAG/CER, TAPE MONI/REC, AUX, DIN jack

Power Supply: 117V
 Dimensions: 15 15/16" (W) x 5 7/16" (H) x 15" (D)
 Weight: 17 5/8 lbs.

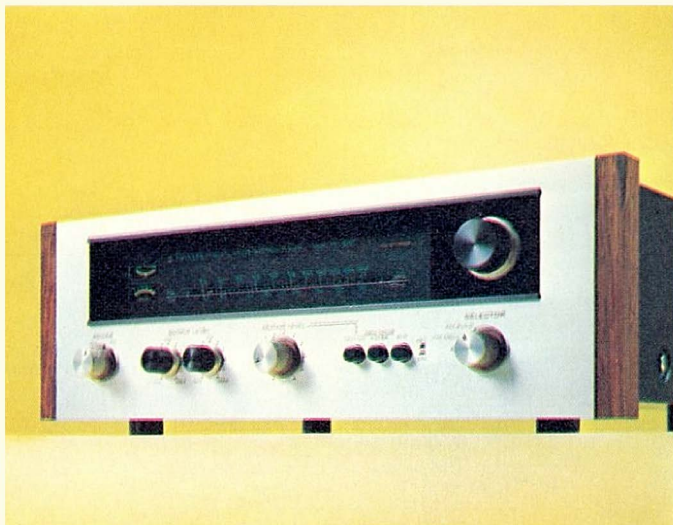

International Design Award

\$259.95

Walnut Cabinet is Optional : \$9.95



\$199.95



\$109.95

Walnut Cabinet is Optional : \$9.95

TX-900

TX-900 AM/FM STEREO TUNER One of the very few professional-type AM/FM tuners made today, this magnificent Pioneer unit is designed for maximum sensitivity and perfect reception even in weak signal areas. The TX-900 features a pair of crystal filters in its IF section for remarkable selectivity and capture ratio. 4-IC's, 3-FET's and a 4-gang variable capacitor in the front-end section provide improved signal to noise ratio and stable reception.

FM Usable Sensitivity: 1.7 μ V (IHF)
 FM Separation: 38dB (at 1KHz)
 Tuning Range: FM: 87.5–108MHz; AM: 525–1,605KHz
 Power Supply: 117V
 Dimensions: 15 ¹⁵/₁₆" (W) x 5 ¹/₂" (H) x 14" (D)
 Weight: 17.2 lbs.

TX-700

TX-700 AM/FM STEREO TUNER New from Pioneer is this extremely sensitive stereo tuner equipped with station presetting pushbuttons that permit finger-tip selection of up to five different FM stations. Other features include noise filter, FM muting circuit and level control for output level adjustment. Handsomely designed with conveniently-placed controls and attractive dial face.

FM Usable Sensitivity: 2.2 μ V
 FM Separation: 42dB (at 1KHz)
 Tuning Range: FM: 87.5–108MHz; AM: 525–1,605KHz
 Power Supply: 110, 117, 130, 220, 240V
 Dimensions: 10 ⁹/₁₆" (W) x 4 ⁵/₈" (H) x 13 ¹/₄" (D)
 Weight: 12 lbs. 5 oz.

TX-500

TX-500 AM/FM STEREO TUNER A valuable addition to even the most expensive stereo set-up, this low-priced AM/FM tuner is rich in features and performance characteristics. For superior reception and sensitivity, the unit uses low noise silicon transistors, a high quality transformer in the 4-stage IF section, and a FET. An envelope detection type demodulator in the FM multiplex circuit provides wide channel separation and excellent stereo results.

FM Usable Sensitivity: 2.5 μ V (IHF)
 FM Separation: 35dB (at 1KHz)
 Capture Ratio: 6 dB (at 98MHz)
 Tuning Range: FM: 87.5–108MHz; AM: 525–1,605KHz
 Power Supply: 117V
 Dimensions: 13" (W) x 5" (H) x 13 ¹/₈" (D)
 Weight: 11 lbs.



\$375.95

SC-100

SC-100 STEREO PREAMPLIFIER This totally professional stereo control amplifier offers near distortion-free sound reproduction and an unusually wide frequency range. Amplifier circuitry consists of high quality E-E feedback 3-stage direct-coupled circuits. It has separated stepped passive tone controls and volume controls of 2dB per step attenuation for precise settings.

Harmonic Distortion: Less than 0.1% (IHF at 4V output, 1,000Hz)
 Frequency Response: 5—50,000Hz ± 1dB
 Maximum Output: 5V
 S/N Ratio: 70dB (PHONO—1, 2/AUX IHF)
 Audio Input: PHONO 1, 2, LOW, TAPE HEAD, TAPE MONI, AUX 1—2, TUNER
 Power Supply: 117V
 Dimensions: 16 3/4" (W) x 6 3/4" (H) x 11 3/4" (D)
 Weight: 14 lbs. 5 oz.



\$129.95

SC-700

SC-700 STEREO PREAMPLIFIER A high quality preamp designed for practical, functional use in any stereo system, the SC-700 is a perfect mate for the Pioneer SM-700 power amp. Features include an equalizer circuit with direct-coupled 3-stage E-E feedback circuit for extreme low distortion, and wide dynamic range.

Harmonic Distortion: Less than 0.05% (at 2V)
 Frequency Response: 10—60,000Hz ± 1dB
 Maximum Output: 4V RMS/less than 0.5% at 1KHz
 S/N Ratio: PHONO: more than 80dB (at 4V IHF)
 Audio Input: PHONO-MAG 1, 2, AUX 1, 2, TUNER
 Power Supply: 117V
 Dimensions: 11 13/16" (W) x 4 1/2" (H) x 10" (D)
 Weight: 9 lbs.



\$375.95

SM-100

SM-100 STEREO POWER AMPLIFIER Coupled with the SC-100 preamplifier, this high-power stereo basic amplifier gives exceptional performance. Music power is 210 watts at 4 ohms and 203 watts at 8 ohms. FET's are employed throughout the input section. The damping factor is variable. Muting is activated automatically for four seconds after power is switched on.

Music Power: 210W (at 4Ω), 203W (at 8Ω)
 Continuous Power: 90W per channel
 RMS Power: 70W + 70W both channel driven (at 8Ω)
 Harmonic Distortion: Less than 0.5% (at 1KHz)
 Frequency Response: 5—100,000Hz ± 1dB
 Power Bandwidth: 10—30,000Hz (H.D. 05% constant IHF)
 Power Supply: 117V
 Dimensions: 16 1/2" (W) x 6 3/4" (H) x 11 3/4" (D)
 Weight: 30 lbs. 13 oz.



\$129.95

SM-700

SM-700 STEREO POWER AMPLIFIER A new medium-power amplifier from Pioneer, this unit features new silicon power transistors, wide frequency response and low distortion characteristics. Offers 120 watts of music power at 4 ohms. Input sensitivity control switch permits adaptation with most any preamplifier now available. For peak performance results, however, Pioneer's SC-700 preamp is recommended.

Music Power: 120W (at 4Ω), 80W (at 8Ω)
 Continuous Power: 42W per channel
 Harmonic Distortion: Less than 0.05% (at 1KHz)
 Frequency Response: 15—60,000Hz ± 0.5dB
 Power Bandwidth: 15—60,000Hz (IHF rating)

Power Supply: 120V
 Dimensions: 11 13/16" (W) x 4 5/8" (H) x 10" (D)
 Weight: 11 lbs. 11 oz.



International Design Award

\$259.95

Walnut Cabinet is Optional : \$9.95

SA-900

SA-900 200 WATT STEREO AMPLIFIER This deluxe Pioneer unit is unparalleled in performance among all professional integrated stereo amplifiers manufactured today. It uses low-noise silicon transistors and a direct-coupled 3-stage E-E feedback circuit for improved frequency response and extremely low distortion. It also has a separated stepped tone controls.

Music Power: 200W (at 4Ω), 145W (at 8Ω)
 Harmonic Distortion: Less than 0.08% (45W, at 1KHz)
 Frequency Response: 20—50,000Hz ± 1dB
 Power Bandwidth: 20—50,000Hz (distortion 0.3% IHF)
 Audio Input: PHONO: MM/MC/CER, MIC, TAPE HEAD, TAPE MONI/REC, TUNER AUX, MAIN-IN, DIN jack

Power Supply: 117V
 Dimensions: 15 15/16" (W) x 5 1/2" (H) x 13 1/32" (D)
 Weight: 27 lbs.



\$199.95

Walnut Cabinet is Optional : \$9.95

SA-700

SA-700 120 WATT STEREO AMPLIFIER Less powerful than the SA-900, but equally at home in the finest professional stereo system, is this 120 watt integrated amplifier from Pioneer. For maximum flexibility, the SA-700 has two sets of speaker outputs and two phono inputs. Hi—Low filters, tested loudness control and special muting switch of—20dB are also included in this unit. It is also provided with a ganged stepped tone controls.

Music Power: 120W (at 4Ω), 85W (at 8Ω)
 Harmonic Distortion: Less than 0.05% (20W, at 1KHz)
 Frequency Response: 20—40,000Hz ± 1dB
 Power Bandwidth: 15—60,000Hz (distortion 0.5% IHF)
 Audio Input: PHONO-1, 2, MAIN-IN, TUNER, TAPE MONI/REC, AUX, DIN jack

Power Supply: 117V
 Dimensions: 14 9/16" (W) x 4 5/8" (H) x 12 5/16" (D)
 Weight: 17 lbs. 10 oz.



\$109.95

Walnut Cabinet is Optional : \$9.95



\$179.95



\$99.95

Walnut Cabinet is Optional : \$9.95

SA-500

SA-500 44 WATT STEREO AMPLIFIER This versatile, compact 44 watt solid state integrated unit fills every medium-power stereo requirement. It features low-noise silicon transistors in the pre-amp section for excellent signal-to-noise ratio and minimal distortion.

Music Power: 44W (at 4Ω), 36W (at 8Ω)
 Harmonic Distortion: Less than 0.5% (at 1KHz rated output)
 Frequency Response: 20—50,000Hz ± 1dB
 Power Bandwidth: 20—40,000Hz (distortion 0.5% IHF)
 Audio Input: PHONO, TUNER, TAPE MONI/REC, TAPE HEAD, AUX, DIN jack
 Power Supply: 117V
 Dimensions: 13" (W) x 4 5/8" (H) x 12 15/16" (D)
 Weight: 13.2 lbs.

SF-700

SF-700 ELECTRONIC CROSSOVER NETWORK An indispensable unit for multi-amplifier stereo systems, this Pioneer network is designed to obtain maximum results from any loudspeaker system. Low and high crossover frequencies can be switched to any of five different frequencies. Attenuation slope characteristics may be changed to any of three different curves. Adaptable for both 2-band or 3-band systems

Crossover Frequency: 125Hz, 250 Hz, 500Hz, 700Hz, 1KHz, 2KHz, 4KHz, 6KHz, 8KHz (2 & 3 band)
 Slope Selection: 6, 12, 18 dB/oct. (LOW, MID-LOW, MID-HIGH, HIGH)
 Power Supply: 120V
 Dimensions: 11 13/16" (W) x 4 1/2" (H) x 10" (D)
 Weight: 9 lbs.

SR-202

SR-202 REVERBERATION AMPLIFIER This solid state unit adds a brilliant "living presence" to the sound reproduced by any stereo system. Its reverberation effect is created by a double-scatter system which blends the two channels of a complex composite sound. The result is sound with tremendous depth, brilliance and natural echoes and reflections.

R.M.S. Output Voltage: 330mV (at 1 KHZ, reverberation time: MIN)
 Harmonic Distortion: Less than 0.2% (at 1 KHZ, reverb. time: MIN)
 Frequency Response: 20—35,000Hz ± 2dB (reverb. time: MAX)
 S/N Ratio: 65dB
 Reverberation Time: 1.9—3.2 sec. (at 1KHz)

Power Supply: 117V
 Dimensions: 11 13/16" (W) x 4 1/2" (H) x 9 13/16" (D)
 Weight: 8.8 lbs.

MULTI-AMP STEREO COMPONENTS

Pioneer's new multi-amplifier stereophonic components provide sound from radio, recordings or tape that is more real, more "alive" than you ever thought possible. A combination of up to three power amplifiers, a pre-amplifier, tuner and electronic crossover network, the system permits perfect matching of the sound source, speaker system (or systems) and individual room acoustics. In multi-amplifier systems, the electrical signals from the pre-amplifier (Model SC-700) are fed directly into the electronic crossover network (Model SF-700) and divided into lows, midrange and highs. These signals are then passed to up to three separate power amplifiers (Model SM-700), one controlling low frequencies, another the middle frequencies, and a third the high frequencies. The signals are next fed to the woofer, midrange speaker or speakers, and tweeter respectively. Since the frequency band of each amplifier is narrow, intermodulation distortion is virtually eliminated and sound reproduction is extraordinary clean. Additionally, the lows, midrange and highs can be boosted or attenuated individually and precisely with controls on the crossover unit. The result is overwhelming realism in sound, a whole new concept in stereo for the dedicated music listener.

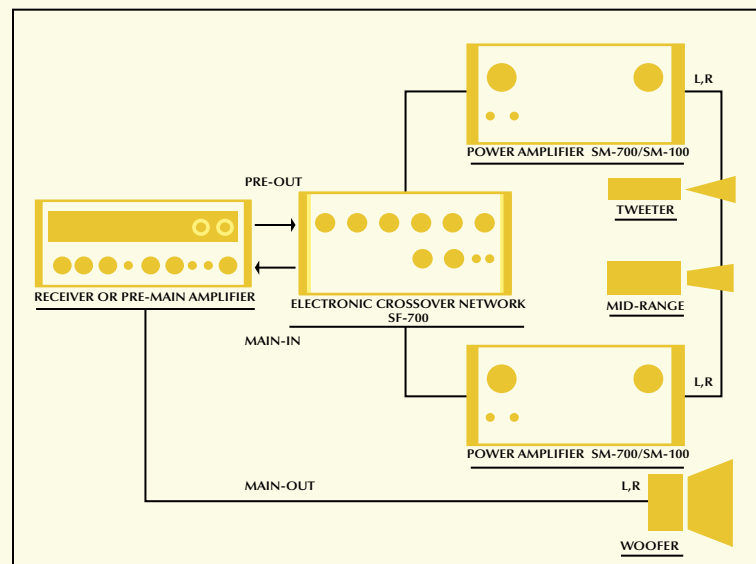
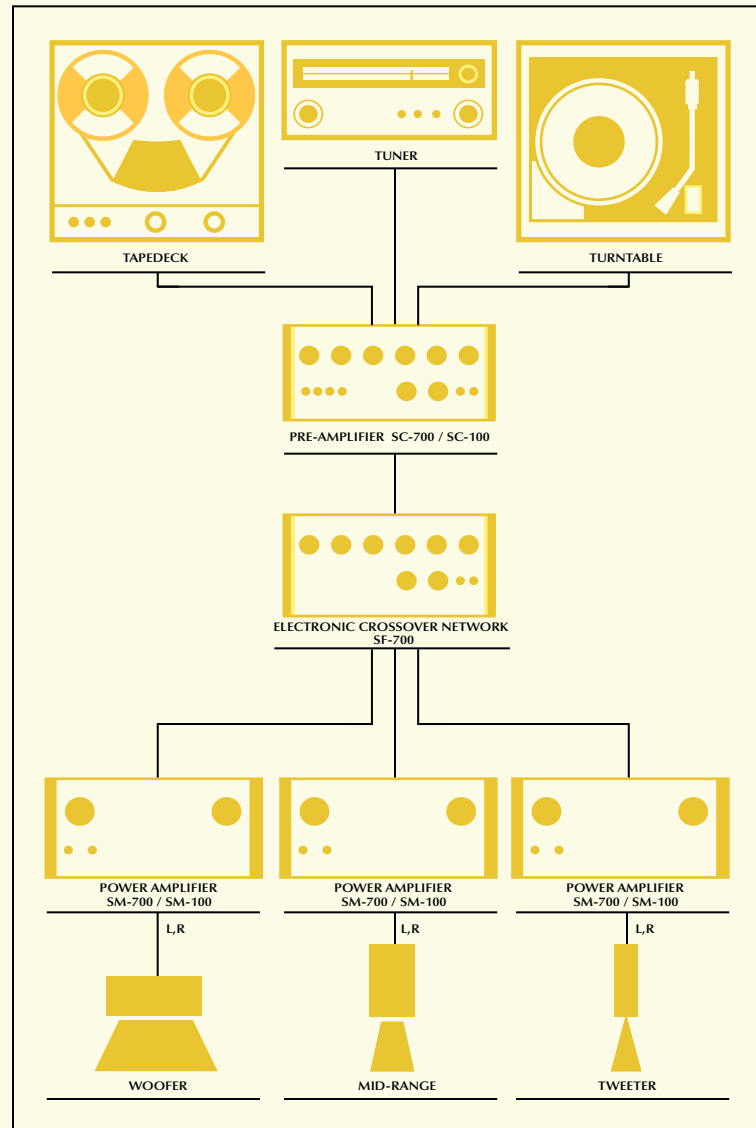

Model SF-700 can be connected to various Pioneer receivers or pre-main amplifiers.

SPEAKER SYSTEMS





\$259.00



\$219.00



\$179.00

CS-63DX

CS-63DX 4-WAY 6-SPEAKER SYSTEM This highly advanced system provides a listening experience to match the outstanding capabilities of Pioneer amplifiers and tuners. It presents a massive 15-inch woofer, two special mid-range units for natural reproduction in the critical mid-range, horn tweeter for moderate highs and two super tweeters for ultra-highs.

Enclosure Type: Air suspension type
 Mounted Speakers: 15" woofer, 5" mid-range x 2, horn tweeter, horn super tweeter x 2
 Impedance: 8Ω
 Frequency Response: 20–22,000Hz
 Maximum Power Input: 80W
 Dimensions: 18⁷/₈" (W) x 28³/₈" (H) x 13¹/₁₆" (D)
 Weight: 63 lbs.

CS-99

CS-99 5-WAY 6-SPEAKER SYSTEM One of Pioneer's most distinguished speaker systems, the CS-99 gives extraordinarily realistic sound from its big 15-inch woofer and five other speakers. This unit features four tweeters which offer a new level of clarity, and wide dispersion of natural sound. Two of these tweeters are the supersonic dome-type for extra brilliance. This system is highly recommended for use with big-power amplifiers.

Enclosure Type: Air suspension type
 Mounted Speakers: 15" woofer, 5" mid-range, horn tweeter, cone super tweeter, dome supersonic tweeter x 2
 Impedance: 8Ω
 Frequency Response: 25–22,000Hz
 Maximum Power Input: 80 watts
 Dimensions: 16" (W) x 25" (H) x 11²/₅" (D)
 Weight: 46 lbs.

CS-A700

CS-A700 3-WAY 3-SPEAKER SYSTEM Another low-distortion system from Pioneer, this speaker unit is equipped with a 12-inch diameter low frequency woofer with cone fabricated by Pioneer's new FB (free-beating) process. A multi-cellular high frequency tweeter contributes to excellent sound dispersion. Overall system is distinguished by crisp bass, clear-cut mid-range tones and high frequency reproduction. Equipped with terminals for multi-amplifier operation.

Enclosure Type: Air suspension type
 Mounted Speakers: 12" woofer, 4³/₄" mid-range, multi-cellular Horn-tweeter
 Impedance: 8Ω
 Frequency Response: 35–20,000Hz
 Maximum Power Input: 60W
 Dimensions: 15" (W) x 26" (H) x 12¹⁹/₃₂" (D)
 Weight: 37.2 lbs.



\$109.00

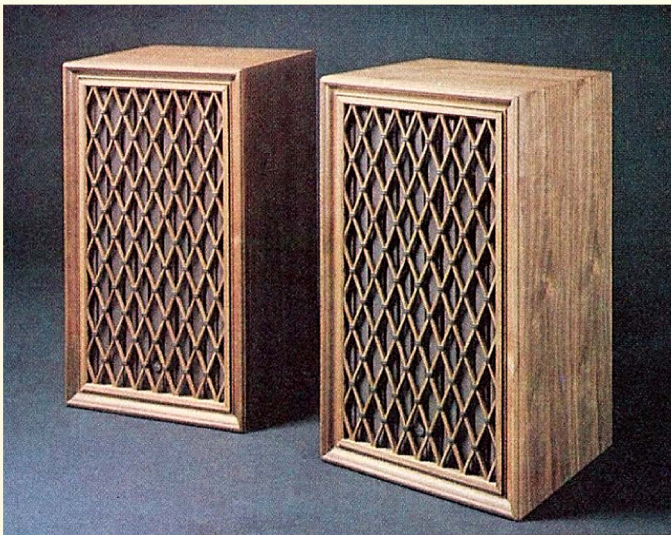

\$149.00



\$69.00

CS-66

CS-66 3-WAY SPEAKER SYSTEM Providing a frequency response range that belies its size, this compact Pioneer speaker system is elegantly designed for home installations of the bookshelf type. A 10-inch woofer provides full-bodied, distortion-free bass responses even at high input power levels and features specifications usually found only in 12-inch type woofers.

Enclosure Type: Air suspension type
 Mounted Speakers: 10" woofer, 6 5" mid-range, cone tweeter
 Impedance: 8Ω
 Frequency Response: 35—20,000Hz
 Maximum Power Input: 40W
 Dimensions: 12³/₁₆" (W) x 22" (H) x 11⁷/₁₆" (D)
 Weight: 29 lbs.

CS-A500

CS-A500 3-WAY 3-SPEAKER SYSTEM Pioneer's new FB (free-beating) process cones are contained in each of this system's loudspeakers for improved efficiency and low distortion. For dynamic punch, each speaker features a 10-inch diameter low frequency woofer. Equipped with terminals for multi-amplifier operation. Handsomely designed.

Enclosure Type: Air suspension type
 Mounted Speakers: 10" woofer, 4³/₄" Cone mid-range, 3" Cone tweeter
 Impedance: 8Ω
 Frequency Response: 40—20,000Hz
 Maximum Power Input: 50W
 Dimensions: 13" (W) x 22⁷/₁₆" (H) x 12¹⁹/₃₂" (D)
 Weight: 32 lbs.

CS-44

CS-44 2-WAY SPEAKER SYSTEM This compact system features a technically advanced two-way air suspension speaker with extremely wide range from deep, perfect lows to well beyond the range of audibility. The enclosure is of oiled walnut, faced by a lattice wood grille. It accepts as much as 25 watts power input, making it ideal for use with either low or high-power amplifiers.

Enclosure Type: Air suspension type
 Mounted Speakers: 8" woofer, 2¹/₂" cone tweeter
 Impedance: 8Ω
 Frequency Response: 35—20,000Hz
 Maximum Power Input: 25W
 Dimensions: 11¹/₈" (W) x 19¹/₈" (H) x 9³/₄" (D)
 Weight: 18 lbs.



\$119.95

CS-05

CS-05 OMNI-DIRECTIONAL LOUDSPEAKER SYSTEM This system represents a major Pioneer sound breakthrough. It provides dynamic "living presence" 360° stereo sound dispersion no matter where you sit in a room, permits unlimited design and sound flexibility. Equipped with Pioneer's FB (free-beating) process cones for clear, crisp sound quality. Attractive columnar design.

Enclosure Type:	Omnidirectional bass reflex type
Mounted Speakers:	8" woofer, 3" cone tweeter x 3
Impedance:	8Ω
Frequency Response:	60—20,000Hz
Maximum Power Input:	40W
Dimensions:	14 ¹ / ₄ " (∅) x 20 ¹ / ₁₆ " (H)
Weight:	27.5 lbs.

**TURNTABLES
& STEREO TAPEDECK**





\$220.00



\$129.95



\$299.95

PL-41A

PL-41A BELT-DRIVE TURNTABLE This Pioneer turntable gives broadcast quality performance at a reasonable price. Wow and flutter is surprisingly low. A 4-pole hysteresis synchronous motor and special precision drive belt give smooth, quiet operation. Tone arm, with magnetic anti-skating device, is elevated and lowered by moving a small lever, thus preventing record damage.

Motor:	4-pole hysteresis synchronous type
Turntable Platter:	12 $\frac{1}{4}$ " diameter aluminum alloy die-cast
Speeds:	45 and 33 $\frac{1}{3}$ " rpm
Wow and Flutter:	Less than 0.08%
Frequency Response:	10—25,000Hz
Cartridge Type:	Induced magnet type (PC-35)
Power Supply:	110, 117, 130, 220, 240V
Dimensions:	20" (W) x 7 $\frac{3}{4}$ " (H) x 16" (D)
Weight:	33 lbs.

PL-A25

PL-A25 BELT-DRIVE TURNTABLE WITH AUTO SHUTOFF A totally new concept in professional turntables, the PL-A25 is equipped with fully automatic systems of lead-in, auto-cutoff and auto-repeat. Only one single-lever operation is required for all functions. Drive motor provides outstanding operational stability. Other features include heavy-duty 12-inch diameter turntable platter and elegant walnut cabinet.

Motor:	4-pole hysteresis synchronous type
Turntable Platter:	12" diameter aluminum alloy die-cast
Speeds:	45 and 33 $\frac{1}{3}$ " rpm
Wow and Flutter:	Less than 0.1%
Frequency Response:	10—25,000Hz
Cartridge Type:	Induced magnet type (PC-35)
Power Supply:	110, 117, 130, 220, 240V
Dimensions:	17 $\frac{5}{16}$ " (W) x 6 $\frac{11}{16}$ " (H) x 13 $\frac{3}{4}$ " (D)
Weight:	16 lbs. 8 oz.

T-600

T-600 AUTO REVERSE STEREO TAPE DECK This totally-professional 4-track 4-head unit is Pioneer's finest tape deck. Its Auto Reverse functions for both recording and playback, permitting extra long play of tapes without reel changing. A swing-up type pinch roller contributes to easy tape loading. Quality performance specifications and independent volume level meters.

Track System:	4-track, 2-channel (stereo recording and playback); 4-track, 1-channel (monaural recording and playback)
Tape Head:	4-track, 2-channel heads x 2
Tape Speed:	7 $\frac{1}{2}$ and 3 $\frac{3}{4}$ ips
Frequency Response:	30—20,000Hz at 7 $\frac{1}{2}$ ips; 30—13,000Hz at 3 $\frac{3}{4}$ ips
Signal-to Noise Ratio:	50dB
Power Supply:	110, 117, 130, 220, 240V
Dimensions:	17 $\frac{1}{4}$ " (W) x 8" (H) x 17 $\frac{1}{8}$ " (D)
Weight:	33 lbs.

STEREO SYSTEMS





\$549.95

C-6000A

C-6000A COMPACT HOME STEREO SYSTEM Distinctively different in design and sound performance, this new three-component unit from Pioneer makes a perfect addition to the home or office. Its central control unit is designed for table placement or on the special leg and its high-quality speaker system may be bookshelf or wall-mounted, allowing unlimited interior design possibilities. The power unit combines an all-solid state amplifier with 36 watt power output, and professional-type AM/FM stereo tuner with outstanding station selectivity and sensitivity. Its fully-automatic turntable does not compromise the quality with an 11-inch diameter die cast zinc platter and 4-pole introduction motor. For perfectly-balanced sound, each compact speaker system features an 8-inch air suspension woofer with remarkably wide frequency range and horn type tweeter for brilliant highs. The central control unit is handsomely finished in walnut and features a reinforced glass cover strong enough to support 550 pounds of weight. The unit may be utilized as a side table to add a touch of elegance to any room's decor.

CENTRAL CONTROL UNIT

Tuning Range:	FM: 87—108 MHz; AM: 525—1,605 KHz
FM Separation:	35dB or better at 1 KHz
Music Power:	36 watts total (at 8Ω, IHF)
Operating Controls:	Tone Controls (Bass, Treble), Loudness Contour Switch, Tape Monitor Switch, TAPE MONI/REC terminals, DIN jack, Stereo Headphone jack, 4-position speaker selector (A, B, A +B, off)
Turntable:	Automatic Turntable (auto lead-in, auto-return, auto-cut, auto-repeat, auto-changer with the long spindle) 33 $\frac{1}{3}$, 45, 78 rpm. Induced magnet type cartridge with 0.6 mil diamond stylus Stylus pressure 2.5 to 3.5 grams
Power Supply:	120V AC, (60Hz)
Dimensions:	20 $\frac{1}{2}$ " (W) x 21 $\frac{5}{16}$ " (H) x 20 $\frac{1}{2}$ " (D)
Weight:	60 lbs. 8 oz.

SPEAKER SYSTEM UNIT

Type:	Air suspension type
Speakers:	8" woofer and horn type tweeter
Dimensions:	11" (W) x 19" (H) x 9" (D)
Weight:	15 lbs. 7 oz.



\$499.95

C-5600

C-5600 HOME STEREO SYSTEM This compact unit from Pioneer is a distinguished engineering triumph. Designed especially for the serious music listener, it offers in one attractive package a multi-amplifier stereo system with professional-quality tuner, record player and speakers, and gives a performance the equal of expensive, individual hi-fi components. Total power for both channels is a big 60 watts, and Pioneer has incorporated separate amplifiers in the speaker system to cover all high frequency ranges and the medium/low frequency range. For perfect speaker balance, each enclosure has an 8-inch woofer and 2 1/2 inch cone tweeter . . . and the sound is predictably brilliant, with outstanding clarity and definition, remarkably low distortion and ideal signal to noise ratio. The AM/FM stereo tuner features the latest FET circuitry for extremely fine selectivity and sensitivity. Mounted atop the tuner/amplifier is a precision belt-driven turntable with automatic tone-arm, lead-in, return, repeat, magnetic type cartridge and quality diamond stylus. And adding to the distinctiveness of the whole unit is its deluxe furniture styling and control accessibility.

CENTRAL CONTROL UNIT

Tuning Range:	FM : 87—108 MHz; AM : 525—1,605 KHz
FM Separation:	More than 35dB (at 1 KHz)
Music Power:	60 W total (at 8Ω, IHF)
Operating Controls	Tone Controls (Bass, Treble), Loudness Contour Switch, Tape MONI/REC terminals, DIN jack, Stereo Headphone jack,
Turntable:	Automatic turntable (auto lead-in, auto-return, auto-cut, auto-repeat, arm elevation), 33 1/3, 45, 78 rpm. Included moving magnet type cartridge with 0.6 mil diamond stylus, Stylus pressure 2.5 to 3.5 grams
Dimensions:	21 1/16" (W) x 8 1/8" (H) x 14 3/16" (D)
Weight:	33 lbs

SPEAKER SYSTEM UNIT

Speakers:	8" woofer, 2-1/2" cone tweeter
Dimensions:	12 3/16" (W) x 22" (H) x 9 3/4" (D)
Weight:	35 lbs x 2

STEREO HEADPHONES

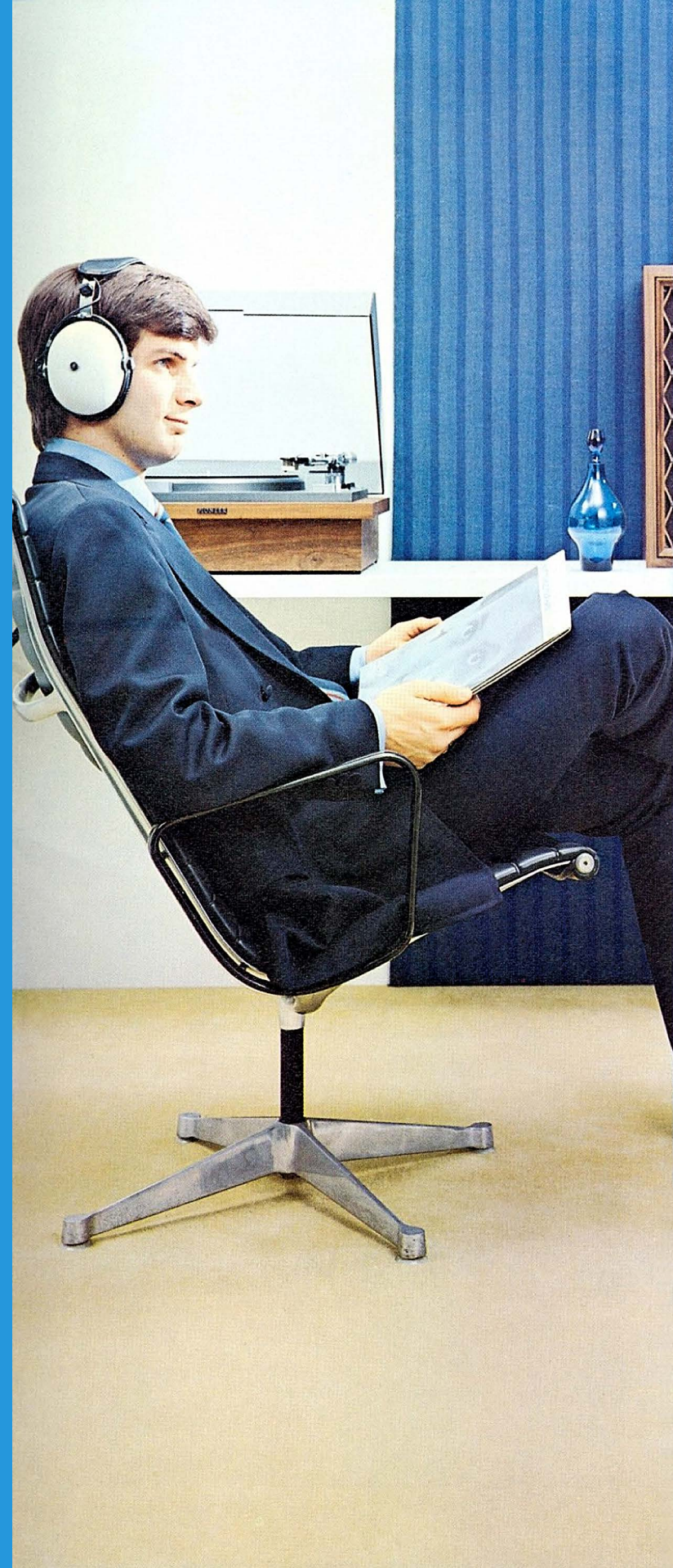



\$49.95



\$34.95



\$24.95

SE-50

SE-50 2-WAY STEREO HEADPHONES Pioneer's finest set of stereo headphones features a 3-inch cone-type element for rich dynamic bass and a horn-type element for clean, rich highs. Volume controls on each earpiece are provided to allow free control of reproduced sounds and for perfect balance of right and left channels. A level control attenuator is provided for the horn-type element. Easy and comfortable to wear, the SE-50 is cushioned for long-wearing without fatigue.

Rated Impedance:	8 Ω
Frequency Response:	20—20,000Hz
Power Handling Capacity:	05.W (each channel)
Weight:	1.35 lbs. (without cord)

SE-30

SE-30 STEREO HEADPHONES Excellent stability and an extremely wide frequency response range are the features of this Pioneer headphones set which is compatible for any stereo system with a headphones jack and an output impedance rating of 4—16 ohms. Tonal quality is soft and free of harsh, strident peaks. Each assembly contains a cone type high fidelity loudspeaker unit designed for headphones use. Headbands are adjustable for perfect, fatigue-free fit.

Rated Impedance:	8 Ω
Frequency Response:	20—20,000Hz
Power Handling Capacity:	05.W (each channel)
Weight:	13.4 oz. (without cord)

SE-20A

SE-20A STEREO HEADPHONES Virtually distortion-free sound is possible from this budget-priced Pioneer headphones set which has a wide frequency response and features usually found only on far more expensive models. The set gives volumes equal to actual concert hall performances with extremely low amplifier or receiver power. It may be used with any stereo system with rated impedance of 4—16 ohms. Styling and shape of the set reflects the finest of human engineering—its lightweight permits long hours of musical enjoyment without fatigue.

Rated Impedance:	8 Ω
Frequency Response:	20—18,000Hz
Power Handling Capacity:	05.W (each channel)
Weight:	13 oz. (without cord)

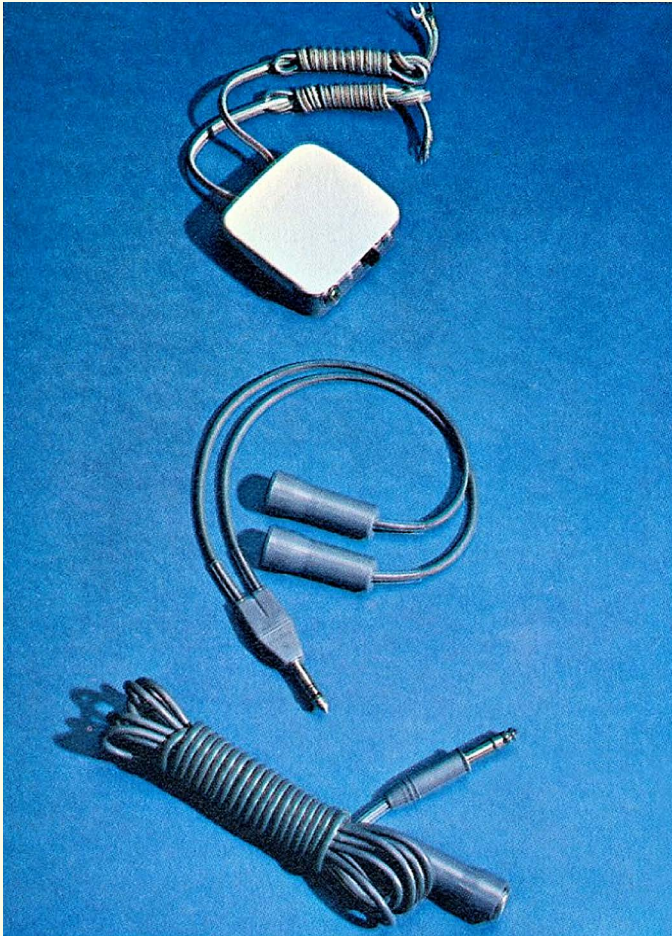

JB-21: \$5.00, JB-22: \$3.00, JB-23: \$3.00

JB-21

JB-21 JUNCTION BOX For stereo systems not equipped with a headphones jack, Pioneer makes this convenient attachment that allows the use of any stereo headphones set. Connects easily to amplifier or receiver, and gives a choice of using headphones only, loudspeakers only or simultaneous operation of both.

JB-22

JB-22 JUNCTION CORD This handy accessory permits the simultaneous operation of two stereophonic headsets. Its input jack fits Pioneer Model JB-21 junction box.

JB-23

JB-23 JUNCTION CORD EXTENSION This 15-foot extension cord allows complete freedom of movement for headphones listening. It fits Pioneer Model JB-22 junction cord or Model JB-21 junction box.

Pioneer Electronic Corporation
Head Office and Main Plant
15-5, 4-chome, Ohmori-Nishi, Ohta-ku,
Tokyo, Japan
Telephone: Tokyo 763-2111

Pioneer Electronics U.S.A. Corporation
178 Commerce Road, Carlstadt,
New Jersey 07072, U.S.A.

Pioneer Electronic (Europe) N.V.
Frankrijklei 64-68, 2000 Antwerp,
Belgium